

SMC8014W-G User Manual



express



Copyright

Information furnished by SMC Networks, Inc. (SMC) is believed to be accurate and reliable. However, no responsibility is assumed by SMC for its use, nor for any infringements of patents or other rights of third parties which may result from its use. No license is granted by implication or otherwise under any patent or patent rights of SMC. SMC reserves the right to change specifications at any time without notice.

Copyright © 2009 by
SMC Networks, Inc.
20 Mason
Irvine, California 92618

All rights reserved.

Trademarks

SMC is a registered trademark of SMC Networks, Inc. Other product and company names are trademarks or registered trademarks of their respective holders.

TABLE OF CONTENTS

CHAPTER 1 | Introduction

- Features and Benefits
- Package Contents
- Minimum Requirements

CHAPTER 2 | Getting to know the EZ Connect™ Wireless Cable Modem Gateway

- LED Indicators
- Rear Panel Description
- Resetting and Restoring the EZ Connect™ Wireless Cable Modem Gateway

CHAPTER 3 | Installation

- Basic Installation Procedure

CHAPTER 4 | Configuring your Computer

- Configuring Windows 95/98/Me
- Configuring Windows 2000
- Configuring Windows XP
- Configuring Windows Vista
- Configuring a Macintosh Computer

CHAPTER 5 | Configuring the EZ Connect™ Wireless Cable Modem Gateway

- Browser Configuration
- Disable Proxy Connection
- Accessing the EZ Connect™ Wireless Cable Modem Gateway Web Management

CHAPTER 6 | Navigating the Web-based Administration

- System
- LAN
- Wireless
- NAT
- Firewall
- Tools
- Status

APPENDIX A | Technical Specifications

APPENDIX B | Compliances

APPENDIX C | Technical Support

CHAPTER 1 | Introduction

Congratulations on your purchase of the EZ Connect™ Wireless Cable Modem Gateway. SMC is proud to provide you with a powerful yet simple communication device for connecting your local area network (LAN) to the Internet.

Features and Benefits

- Internet connection to cable modem service via an integrated cable modem port
- Local network connection via 10/100 Mbps Ethernet ports, USB 1.1 port, or 54 Mbps wireless
- 802.11g - interoperable with multiple vendors
- Wireless WEP, WPA, and WPA2 encryption, Hide SSID, and MAC Filtering
- DHCP for dynamic IP configuration, and DNS for domain name mapping
- Firewall with Stateful Packet Inspection, client privileges, hacker prevention, DoS, and NAT
- User-definable application-sensing tunnel supports applications requiring multiple connections
- Built-in Parental controls allow you to limit certain web sites - configurable by time and day
- Easy setup through a web browser on any operating system that supports TCP/IP
- Compatible with all popular Internet applications



Package Contents

Before installing the EZ Connect™ Wireless Cable Modem Gateway, verify that you have the items listed below. Also be sure that you have the necessary cabling. If any of the items are missing or damaged, contact your local SMC distributor.

- 1 - EZ Connect™ Wireless Cable Modem Gateway
- 1 - Power adapter (12V/1.25A)
- 1 - CAT-5 Ethernet cable
- Installation CD, including:
 - User Guide
 - USB Drivers

If possible, retain the carton and original packing materials in case there is a need to return the product.

System Requirements

You must meet the following minimum requirements:

- Provisioned Internet access from a cable operator that has approved the SMC8014W-G
- A computer equipped with a wired network adapter with TCP/IP installed
- A Java-enabled web browser, such as Microsoft Internet Explorer 5.5 or above
- Windows 98 Second Edition or higher is required for USB driver support.

CHAPTER 2 | Getting to Know the EZ Connect™ Wireless Cable Modem Gateway

The EZ Connect™ Wireless Cable Modem Gateway is the perfect all-in-one solution for the home or business environment. This full-featured device has:

- An approved DOCSIS 1.1 and 2.0 cable modem
- Advanced SPI Firewall Gateway
- High-speed 54 Mbps 802.11g Wireless Access Point
- Comprehensive LEDs for network status and troubleshooting
- Reset Button
- 4 - 10/100 Mbps Auto-Sensing LAN ports with Auto-MDI/MDIX feature
- 1 - USB 1.1 LAN Port for PC connectivity

NOTE: Cable modems can provide up to 38 Mbps downstream and 10 Mbps upstream. However, you should note that the actual rate provided by specific service providers may vary dramatically from these upper limits.

LED Indicators

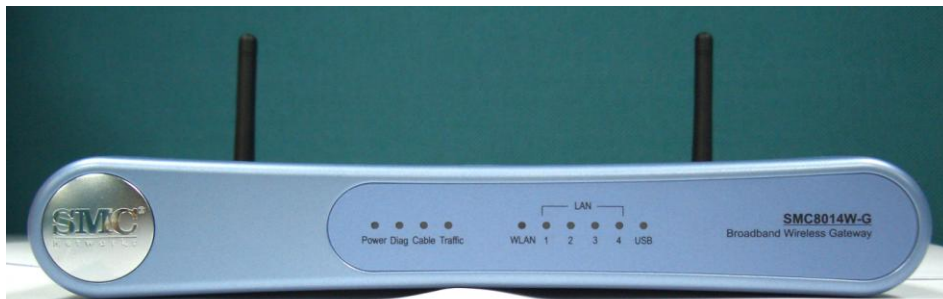

The Gateway includes LED indicators on the front panel that simplify installation and network troubleshooting.

LABEL	LED COLOR	ON	FLASHING	OFF
Power	Green	Power is supplied to the Gateway	N/A	Power is not supplied to the Gateway
Diag	Green	System Failure. Reboot Gateway	N/A	Normal Operation
Cable	Green	Successfully connected to the RF network - upstream ranging completed	Attempting to connect to RF network	N/A
Traffic	Green	Cable Modem has finished CMTS registration. Internet connectivity completed	Attempting to register with CMTS	N/A
WLAN	Green	Wireless Link	Data transmitting	No Wireless Link
LAN (1-4)	Green	Connected at 10 or 100 Mbps	Data transmitting	No Ethernet link detected
USB	Green	USB port connected	Data transmitting	No USB link detected

Rear Panel Description

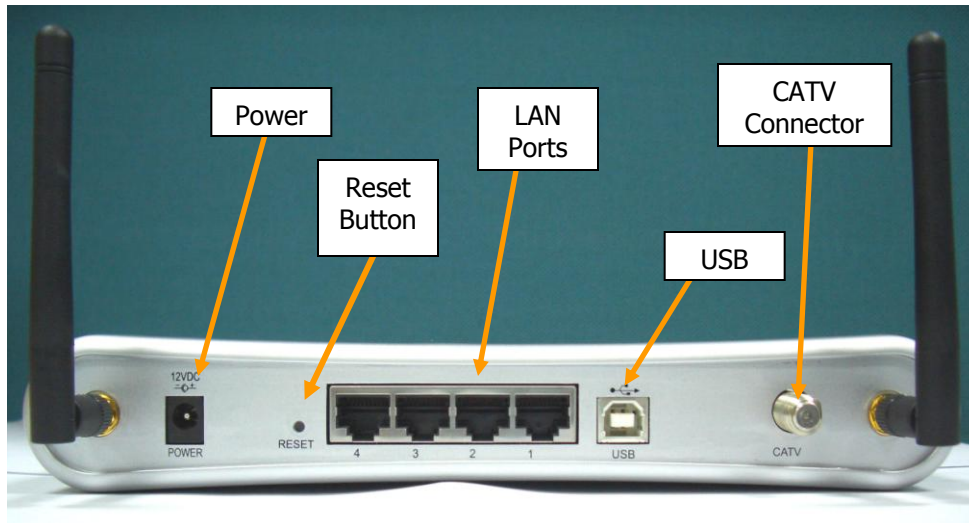

Item	Description
Power	Connect the included power adapter to this port.
Reset	Use this button to reset the power or restore the default factory settings.
LAN 1-4	Four 10/100 Auto-sensing switch ports (RJ-45). Connect devices on your local area network to these ports (such as a PC, hub, or switch).
USB	Connect a USB Cable from your PC to this port.
CATV	Connect your cable line to this port.

Rebooting and Restoring the EZ Connect™ Wireless Cable Modem Gateway

The Reset button is located on the rear panel of the Gateway. Use a paper clip or a pencil tip to push the Reset button.

Reboot

If the Gateway is having problems connecting to the Internet, simply hold down the reset button for less than 2 seconds then release.

Restore Factory Defaults

If rebooting the Gateway does not resolve your issue, then you can follow these steps:

1. Leave power plugged into the Gateway.
2. Locate the reset button on the back panel, press and hold button for at least 10 seconds.
3. Release reset button.

CHAPTER 3 | Installation

The EZ Connect™ Wireless Cable Modem Gateway can be installed in any location where you have cable Internet access, and your cable Internet service provider has approved the Gateway. To confirm you meet these 2 criteria points, please contact your cable operator.

For general installation please follow the guidelines outlined below to best performance:

- Allow sufficient air flow around the device to assist in keeping the device as cool as possible
- Do not place the Gateway in a dusty or wet environment.
- For optimum wireless performance, install the Gateway away from other electronic devices, such as Monitors / TV / 2.4GHz Cordless Phones. These devices can hamper your wireless throughput and distance.

Basic Installation Procedure

1. **Connect the LAN:** You can connect the Gateway to your PC, or to a hub or switch. Run Ethernet cable from one of the LAN ports on the rear of the Gateway to your computer's network adapter or to another network device. You can use either a standard straight through or crossover Ethernet cable since the Gateway incorporates Auto-MDI/MDIX functionality.

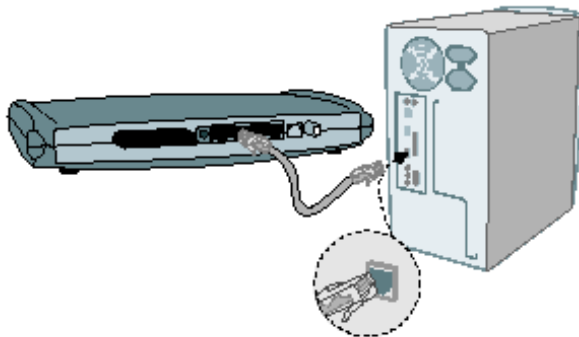

2. **Connect the WAN:** Connect a coaxial cable to the CATV port on the back of the Gateway from a cable port located in your home. When connecting to the CATV port, use only manufactured coaxial patch cables with F-type connectors at both ends for all connections.

Note: If this modem was NOT installed by your cable provider (ISP) or is being used to replace another cable modem - please contact your Cable Operator to register the SMC8014W-G. If the modem is not registered with your cable operator it will be unable to connect to the cable network system.

3. **Power on:** Connect the power adapter to the Gateway.

Warning: Only use the power adapter that was provided with the Gateway! Using another power adapter may damage your unit and void the warranty.

CHAPTER 4 | Configuring your Computer

The information outlined in this chapter will guide you through the configuration for the following Operating Systems:

- Windows 95/98/ Me
- Windows 2000
- Windows XP
- Windows Vista
- Apple Macintosh

Configuring Windows 95/98/Me

1. Access your Network settings by clicking [Start], choose [Settings], and then select [Control Panel].
2. In the Control Panel, locate and double-click the [Network] icon.
3. Highlight the TCP/IP line that has been assigned to your network card on the [Configuration] tab of the [Network] properties window. (see network dialog box to the right)
4. Next, click the [Properties] button to view that adapter's TCP/IP settings.
5. From the TCP/IP Properties dialog box, click the [Obtain an IP address automatically] option. (see TCP/IP dialog box to the right)
6. Next click on the [Gateway] tab and verify the Gateway field is blank. If there are IP addresses listed in the Gateway section, highlight each one and click [Remove] until the section is empty.
7. Click the [OK] button to close the TCP/IP Properties window.
8. On the Network Properties Window, click the [OK] button to save these new changes.

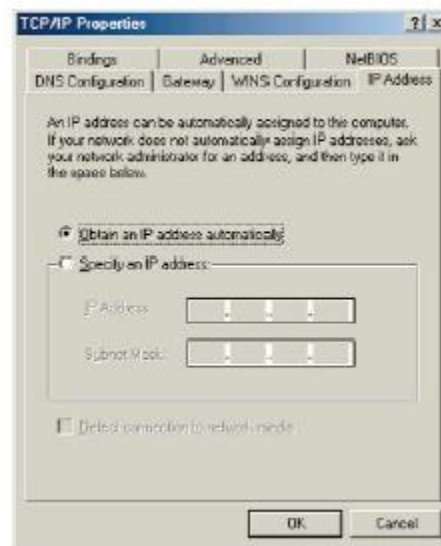
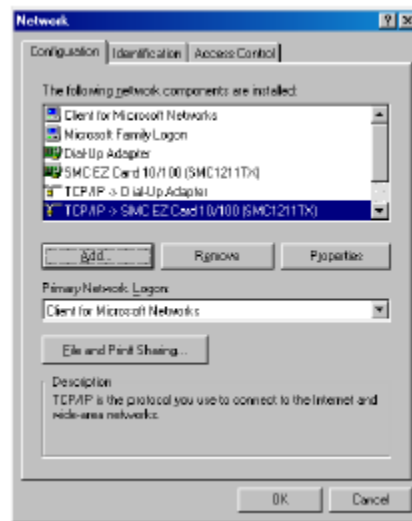

NOTE: Windows may ask you for the original Windows installation disk or additional files. Check for the files at c:\windows\options\cabs, or insert your Windows CD-ROM into your CD-ROM drive and check the correct file location, for example, D:\win98, D:\win9x. (In this example "D" is your CD-ROM drive).

9. Windows may prompt you to restart the PC. If so, click the [Yes] button. If Windows does not prompt you to restart your computer, do so anyway to ensure your settings.

Configuring Windows 2000

1. Access your Network settings by clicking [Start], choose [Settings], and then select [Control Panel]
2. In the Control Panel, locate and double-click the [Network and Dial-up Connections] icon
3. Locate and double-click the [Local Area Connection] icon for the Ethernet adapter that is connected to the Gateway. When the Status dialog box window opens, click the [Properties] button.
4. On the [Local Area Connection] Properties box, verify the box next to Internet Protocol (TCP/IP) is checked. Then highlight the Internet Protocol (TCP/IP), and click the Properties button.
5. Select Obtain an IP address automatically to configure your computer for DHCP. Click the [OK] button to save this change and close the Properties window.
6. Click the [OK] button again to save these new changes.
7. Reboot your PC.

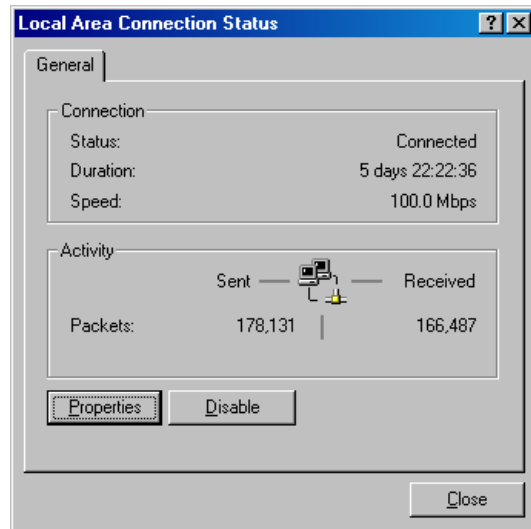

Configuring Windows XP

The following instructions assume you are running Windows XP with the default interface. If you are using the Classic interface (where the icons and menus look like previous Windows versions), please follow the instructions for Windows 2000 outlined above.

1. Access your Network settings by clicking [Start], choose [Control Panel], select [Network and Internet Connections] and then click on the [Network Connections] icon.
2. Locate and double-click the Local Area Connection icon for the Ethernet adapter that is connected to the Gateway. Next, click the [Properties] button.
3. On the [Local Area Connection] Properties box, verify the box next to Internet Protocol (TCP/IP) is checked. Then highlight the Internet Protocol (TCP/IP), and click the Properties button.
4. Select Obtain an IP address automatically to configure your computer for DHCP. Click the [OK] button to save this change and close the Properties window.
5. Click the [OK] button again to save these new changes.

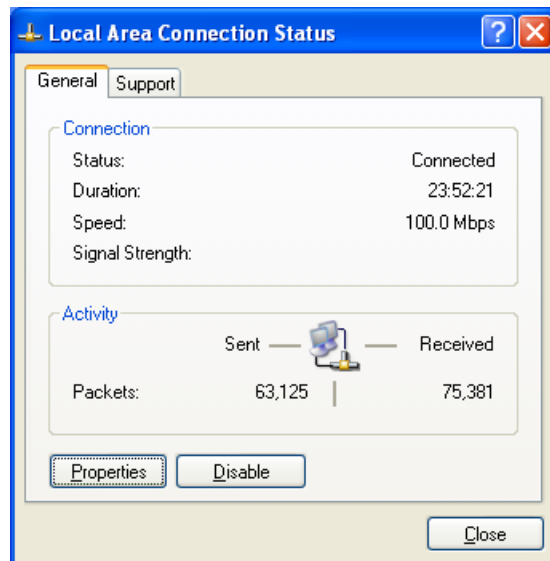

6. Reboot your PC.

Configuring Windows Vista

The following instructions assume you are running Windows Vista with the default interface. If you are using the Classic interface (where the icons and menus look like previous Windows versions), please follow the instructions for Windows 2000 outlined above.

1. Access your Network settings by clicking [Start], choose [Control Panel], select [Network and Internet Icon] and then click on the [View Networks Status and tasks]. Click on the [Management Networks Connections]
2. Locate and Right click the Local Area Connection icon. Click the [Properties] button. Next, click [Continue].
3. On the [Local Area Connection] Properties box, verify the box next to Internet Protocol (TCP/IPv4) is checked. Then highlight the Internet Protocol (TCP/IPv4), and click the Properties button.

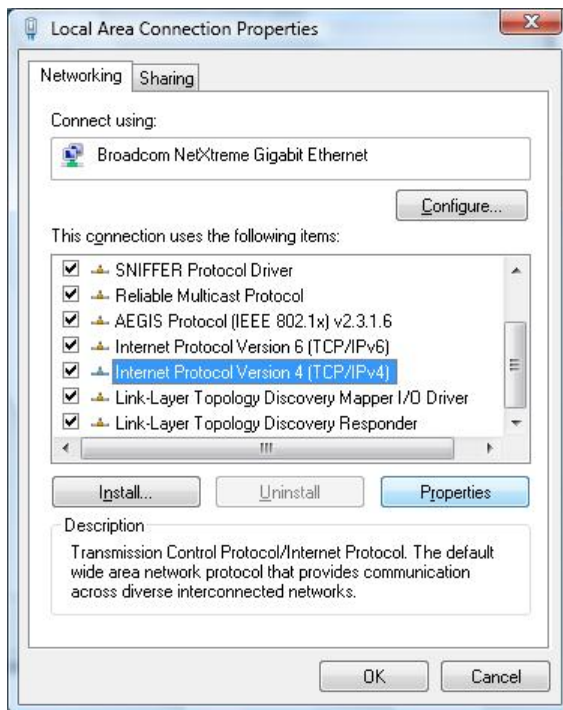

4. Select Obtain an IP address automatically to configure your computer for DHCP. Click the [OK] button to save this change and close the Properties window.

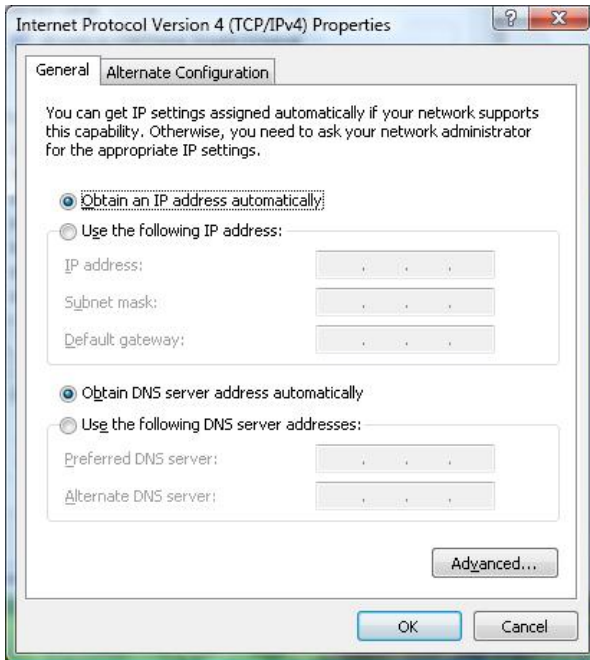

5. Click the [OK] button again to save these new changes.

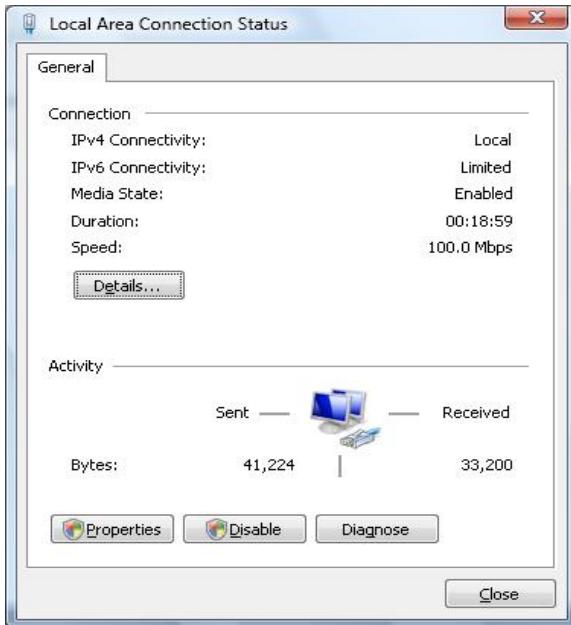

Configuring a Macintosh Computer

You may find that the instructions here do not exactly match your screen. This is because these steps and screen shots were created using Mac OS 10.2. Mac OS 7.x and above are all very similar, but may not be identical to Mac OS 10.2.

1. Pull down the Apple Menu. Click System Preferences and select Network.
2. Verify that adapter connected to SMC8014W-G is selected in the Show field.
3. On the TCP/IP tab, select “Using DHCP” in the Configure field.
4. Close the TCP/IP dialog box by clicking on “Apply Now”.

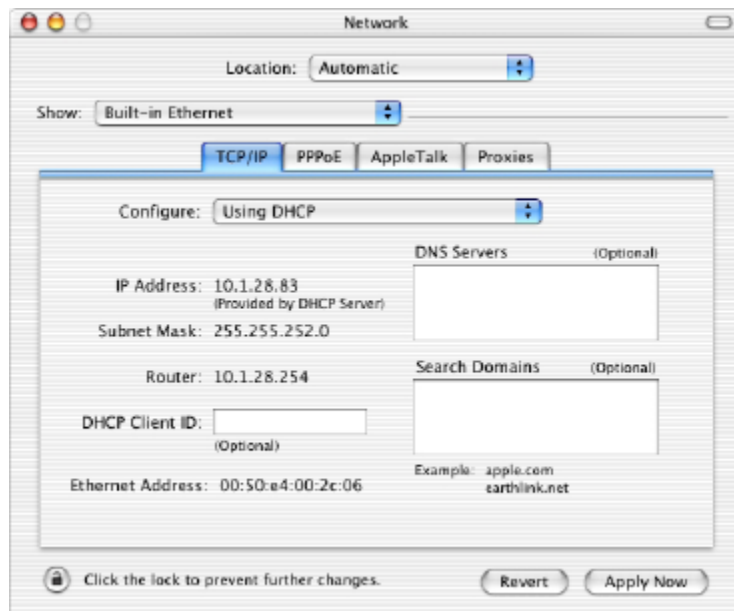

CHAPTER 5 | Configuring the EZ Connect™ Wireless Cable Modem Gateway

After you have configured TCP/IP on a client computer, use a web browser to configure the EZ Connect™ Wireless Cable Modem Gateway. The Gateway can be configured by any Java-supported browser including Internet Explorer 5.0 or above. Using the web management interface, you can configure the Gateway features and view its settings.

Before you attempt to log into the Gateway's Web-based Administration, please verify the following:

1. Your browser is configured properly. (see below)
2. Disable any firewall or security software that may be running.
3. Confirm that you have a [link] LED where your computer is plugged into the Gateway. If you don't have a [link] light, try another cable.

Browser Configuration

Confirm that your browser is configured for a direct connection to the Internet. This is configured through the [Tools] then [Options/Preferences] section of your browser.

Disable Proxy Connection

You will also need to verify that the "HTTP Proxy" feature of your web browser is disabled. This is so that your web browser will be able to view the web-based configuration pages. The following steps are for Internet Explorer and for Netscape. Determine which browser you use and follow the appropriate steps.

Internet Explorer (5.0 or above)

1. Open Internet Explorer. Click [Tools], and then select [Internet Options].
2. In the [Internet Options] window, click the [Connections] tab.
3. Click the [LAN Settings] button.
4. Clear all the check boxes and click [OK] to save these LAN settings changes.
5. Click [OK] again to close the [Internet Options] window.

NOTE: To ensure proper screen refresh after a command entry, be sure that Internet Explorer 5.0 is configured as follows: Under the menu "Tools/Internet Options/General/Temporary Internet Files/Settings," the setting for "Check for newer versions of stored pages" should be "Every visit to the page."

Accessing the EZ Connect™ Wireless Cable Modem Gateway's Web Management

To access the EZ Connect™ Wireless Cable Modem Gateway's web-based management screens, follow the steps below:

1. Launch a web-browser.

NOTE: Your computer does not have to be ONLINE to configure the EZ Connect™ Wireless Cable Modem Gateway.

2. In the Address Bar, type: **http://192.168.0.1**

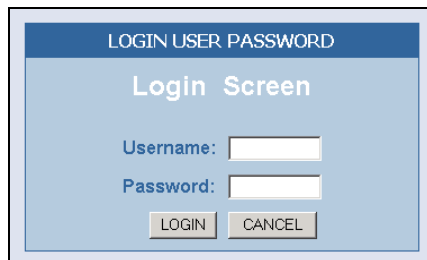

3. When the Gateway's Login screen appears, enter the default username and password, and click the [Login] button to access the Gateway.

A screenshot of the Gateway's Login Screen. The screen has a blue header with the text "LOGIN USER PASSWORD". Below the header, the text "Login Screen" is displayed. There are two input fields: "Username:" and "Password:". Below the input fields are two buttons: "LOGIN" and "CANCEL".

Default Username and Password:

USERNAME: cusadmin
PASSWORD: password

NOTE: Usernames and Passwords are case sensitive

4. Once logged into the Gateway's web-based administration screen, there are several options and features which can be configured, as outlined in the following chapter.

CHAPTER 6 | Navigating the Web-based Administration

The EZ Connect™ Wireless Cable Modem Gateway's management interface allows you to configure both basic and advanced features and options. Some of these advanced functions include: hacker attack detection, IP and MAC address filtering, intrusion detection, port forwarding setup, virtual DMZ hosts, as well as other advanced functions.

Making Configuration Changes

Once a configuration change has been made on a page, be sure to click the [Apply] or [Next] button at the bottom of the page to enable the new setting.

SYSTEM

Password Settings

To access the Password Settings configuration page, click on [System] link and then click on the [Password Settings] link on the Side Navigation bar.

A new password can be configured for the [cusadmin] account in this section.

The Idle Time Out value can also be specified on this page. The default Idle Time Out value is 10 minutes. If there is no activity after this amount of time, the administrator will automatically be logged out.

Password Settings

Set a password to restrict management access to the SMC8014WG. Also a timeout value could be set here for automatic logout if the page is not active for the timeout period.

- Current Password :
- New Password :
- Re-Enter Password for Verification :
- Idle Time Out : Min

HELP APPLY CANCEL

If your password is lost or you cannot gain access to the user interface, press the Reset button on the rear panel (holding it down for at least five seconds) to restore the factory defaults.

NOTE: After a reset, all custom settings will be deleted!

LAN

From this section you can configure the following settings:

- The **PRIVATE** LAN IP settings, including IP Address, Subnet Mask, and Domain Name.
- Enable or Disable the integrated DHCP server
- Configure the DHCP Lease time for your DHCP clients

To access the LAN configuration page, on the Side Navigation bar, click on [LAN] link.

LAN IP

Use the LAN section to configure the LAN IP address for the Gateway and to enable the DHCP server for dynamic client address allocation. You can also configure the Lease Time for the DHCP clients on your network.

Private LAN IP Settings

Define the Gateway's private LAN settings. The IP address configured in the example below (192.168.0.1) is the Gateway's (default setting: 192.168.0.1).

NOTE: Port Forwarding and Access Control rules will be based on the network scope defined here. If either of these types of rules were previously setup and the Private LAN IP address is changed, those rules will need to be recreated to reflect the new Private LAN IP network.

LAN Settings

Users can set up the private LAN IP in this page. The private LAN IP is also the IP of the DHCP server which will dynamically allocate IP address for the client PCs behind the Gateway. The private IP range is a class C address.

Private LAN IP

IP address	192 168 0 1
IP Subnet Mask	255 255 255 0
Domain Name	mygateway.net
Enable DHCP Server	<input checked="" type="checkbox"/>
Lease Time	One Week

HELP APPLY CANCEL

DHCP Server Settings

The Gateway's DHCP Server can be enabled/disabled here. Also the DHCP client Lease Time can be adjusted from the default setting of "One Week." The Gateway functions as a DNS proxy by default.

Enable DHCP Server	<input checked="" type="checkbox"/>
Lease Time	One Week

WIRELESS

This section allows you to configure the Gateway's built-in 54 Mbps 802.11g Access Point. To setup the wireless connections, you will need to do define the Service Set Identifier (SSID), Channel, Encryption options, and other optional settings.

To access the Wireless Settings page shown below, on the Side Navigation bar, click on [Wireless] link.

The Wireless Mode can be set to Mixed (default), 11B only, 11B+ only, or 11G only. Also, the Gateway's wireless interface can be disabled if not being used.

Wireless Settings

The gateway can be quickly configured as a wireless access point for roaming clients by setting the access identifier and channel number. It also supports data encryption and client filtering. Users could also choose which mode would be run for this access point. There are 11b, 11b+, 11g, or mixed mode. If necessary, users can also disable the wireless module by checking the **Disable Wireless Module** checkbox.

Mixed mode
 11B only
 11B+ only
 11G only

Disable Wireless Module

HELP APPLY CANCEL

Channel and SSID

You must specify a common radio channel and SSID (Service Set ID) to be used by the Gateway and all of your wireless clients. Be sure you configure all of your clients to the same values.

To access the Channel and SSID configuration page, on the Side Navigation bar, click on [Wireless] link and then click on the [Channel and SSID] link.

Channel and SSID

This page allows you to define SSID and Channel ID for wireless connection. In the wireless environment, this gateway can be acting as a wireless access point. These parameters are used for the mobile stations to connect to this access point.

SSID	WLAN
Channel	1

Hide SSID

HELP APPLY CANCEL

SSID: This is the Wireless ID or Service Set ID of your wireless network. This should be set to the same value as the other wireless devices in your network.

NOTE: The SSID is case sensitive and can consist of up to 32 alphanumeric characters.

Channel: The radio channel through which the Gateway communicates to clients over the wireless network.

NOTE: If you are not getting good wireless performance try another wireless channel - because the Gateway operates in the 2.4GHz spectrum - it can be affected by some other products, such as cordless phones.

Hide SSID: This option will cause the Gateway to not broadcast its SSID. By selecting this option, wireless clients will not be able to use their Site Survey feature to locate this wireless network.

Encryption

If you are transmitting sensitive data across wireless channels, you should enable either Wired Equivalent Privacy (WEP) or WiFi Protected Access (WPA) encryption. Encryption requires you to use the same set of encryption/decryption keys for the Gateway and all of your wireless clients.

To access the Encryption configuration page, on the Side Navigation bar, click on [Wireless] link and then click on the [Encryption] link.

Encryption

Encryption transmits your data securely over the wireless network. Matching encryption keys must be setup on your Residential Wireless Gateway and wireless client devices to use encryption.

Security None

Authentication Type WPA-PSK
WEP
WPA2-PSK

WPA Passphrase

WEP KEY

64 Bit

128 Bit

WEP

Select [WEP] from the [Encryption Type] drop down menu. Select the Automatic, Open System, or Shared Key from the [WEP Authentication Type] drop down menu.

Authentication Type Shared Key

Automatic
Open System
Shared Key

WPA Passphrase

You can choose between standard 64-bit or 128-bit encryption keys. Below are the configuration options for 64-bit WEP. A passphrase or a manual key can be used.

NOTE: To enter a manual WEP key you will need to enter hexadecimal values (A-F and 0-9).

WEP KEY

64 Bit

Key 1 0x0000000000

Key 2 0x0000000000

Key 3 0x0000000000

Key 4 0x0000000000

Default Key 1

128 Bit

Passphrase

Generate Keys

To automatically generate a 64-bit WEP key, enter in a Passphrase (keyword - ex. Home) and click the [Generate Keys] option. Once you do this, the Gateway will dynamically generate 4 keys. Simply configure the Default Key to the one key that you will be using across your

network.

On the wireless clients, you can use the passphrase option, and client utility will generate the same 4 keys - or you can manually type in the selected KEY that is configured on the Gateway.

For more security, you can use 128-bit WEP encryption. To use this mode, click the [128 Bit Encryption] option and the configuration section will be displayed. You can manually enter in the 26-digit hexadecimal key or use the passphrase option to generate random dynamic keys.

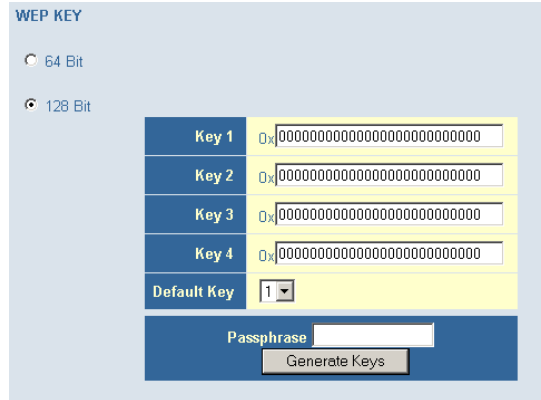

NOTE: If you are having a difficult time getting the wireless connection up after enabling WEP - please confirm that you have configured the SAME WEP key on both the Gateway and Client card.

WPA-PSK

Select [WPA-PSK] from the [Encryption Type] drop down menu. Next, enter a passphrase value between 8 and 63 characters in the [WPA Passphrase] field.



WPA2-PSK

Select [WPA2-PSK] from the [Encryption Type] drop down menu. Next, enter a passphrase value between 8 and 63 characters in the [WPA Passphrase] field.

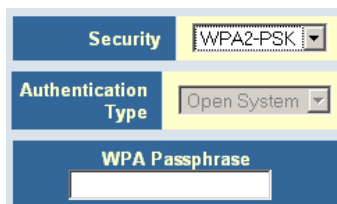

MAC Filtering

The Gateway can allow the wireless client stations to connect over a wireless connection in 2 different ways:

1. By allowing all wireless stations access;
2. Or by allowing only Trusted PCs.

To access the MAC Filtering configuration page, on the Side Navigation bar, click on [Wireless] link and then click on the [MAC Filtering] link.

You can also configure a [Device Name] that is associated with a specific MAC address. In doing this, you can easily recognize the computers that you are in your access list. **NOTE:** MAC filtering only applies to Wireless Clients.

NAT

Network Address Translation (NAT) allows multiple users at your local site to access the Internet through a single public IP address.

Port Forwarding

The Gateway supports port forwarding that enables customers to host servers on their LAN. You can configure this feature to redirect the external service request to the appropriate internal server and port.

For example, if you are running a WEB server, you can configure all traffic on port 80 to be redirected to the IP address of the WEB server running on your network.

To access the Port Forwarding configuration page, on the Side Navigation bar, click on [NAT] link and then click on the [Port Forwarding] link.

This Port Forwarding function supports 2 types of Services:

- Predefined Service
- Customer Defined Service

Predefined Service

The Predefined Service option has a pull-down menu with several popular Service Applications, such as HTTP (80), FTP (20/21), and AIM/ICQ (5190).

The screenshot shows a web-based configuration interface for a 'Predefined Service'. The title is 'Predefined Service' in blue. Below the title is a descriptive sentence: 'Predefined service allows users to choose the traffic type to be allowed-in from Internet.' The form consists of several rows with labels on the left and input fields on the right. The 'Service' row has a dropdown menu with 'AIM/ICQ(TCP:5190)' selected. The 'LAN Server IP' row has four input boxes containing '192', '168', '0', and an empty box. The 'Remote IPs' row has a dropdown menu with 'Any' selected. The 'Start IP' row has four input boxes, each containing '0'. The 'End IP' row has four input boxes, each containing '0'. At the bottom right of the form are three buttons: 'Back', 'Apply', and 'Cancel'.

Service	AIM/ICQ(TCP:5190)
LAN Server IP	192 . 168 . 0 .
Remote IPs	Any
Start IP	0 . 0 . 0 . 0
End IP	0 . 0 . 0 . 0

Back Apply Cancel

To configure Port Forwarding with a Predefined Service rule, follow the steps below:

1. Select the [Service] that you want to have access through the firewall to your LAN from the pull-down menu.
2. Enter in the [LAN Server IP] for the LAN PC that is running this service or application
3. You can also configure [Remote IPs] option to allow access to this specific port from the WAN side. This can be configured for 3 different access types:
 - a. Any IP Address [Any] - choose this option to allow access from any public IP address.
 - b. Single IP Address [Single Address] - choose this option to only allow access from a single public IP address.
 - c. IP Address Range [Address Range] - choose the option to only allow a range of public IP addresses.
4. Click the [Apply] button to save your changes and return to the Port Forwarding main screen

Customer Defined Service Rule (Custom)

The Customer Defined Service section allows you to custom configure a Port Forwarding rule with any Traffic type (TCP/UDP/TCP and UDP), Public Port, and Private Port.

Customer Defined Service

Customer-defined service allows users to define their traffic type to be allowed-in from Internet.

Name	<input type="text"/>
Type	TCP
LAN Server IP	192 . 168 . <input type="text"/> . <input type="text"/>
Remote IPs	Any
Start IP	<input type="text"/> . <input type="text"/> . <input type="text"/> . <input type="text"/>
End IP	<input type="text"/> . <input type="text"/> . <input type="text"/> . <input type="text"/>
Public IP Ports	Port Range
Start Public Port	<input type="text"/>
End Public Port	<input type="text"/>
Private Ports	<input type="text"/> <input type="checkbox"/> Enable Port Range

Back Apply Cancel

To configure this custom option, please follow the steps below:

1. Enter in a Description [Name] for this custom setting
2. Configure the Traffic or Data [Type] that you want to forward. The options are *TCP* | *UDP* | *TCP/UDP*.
3. Set the [LAN Server IP] of the PC that you want this traffic/data redirected to
4. You can also configure [Remote IPs] option to limit access to this specific port from the WAN side. This can be configured for 3 different access types:
 - a. Any IP Address [Any] - choose this option to allow access from any public IP address.
 - b. Single IP Address [Single Address] - choose this option to only allow access from a single public IP address.
 - c. IP Address Range [Address Range] - choose the option to only allow a range of public IP addresses.
5. Set the [Start Public Port] and [End Public Port] that this application will use on the WAN (Internet) side. The Gateway will listen for incoming traffic/data to its WAN IP on these ports.
6. Set the [Private Ports] that the Gateway will forward this traffic to on the LAN. If there is a range of ports, enter the starting private port in [Private Ports], select [Enable Port Range] checkbox, and the Gateway will automatically calculate the end private port. The LAN PC server will listen for traffic/data on this/these ports.

Below is an example setting for a Web server on an Internet connection, where port 80 is blocked from the WAN side, but port 8000 is available.

Name: Web Server
 Type: TCP
 LAN Server IP: 192.168.0.100
 Remote IPs: Any (allow access to any public IP)
 Public Port: 8000
 Private Port: 80

With this configuration, all HTTP (Web) TCP traffic on port 8000 from any IP Address from the WAN side will be redirected through the firewall to the Internal Server (192.168.0.100) on port 80.

NOTE: This configuration is useful because you don't have to reconfigure your web server to accept traffic on a different port, this configuration can be done on the Gateway.

FIREWALL

The Gateway provides a stateful inspection firewall (SPI), which is designed to protect against Denial of Service (DoS) attacks. Its purpose is to allow a private local area network (LAN) to be securely connected to the Internet. To provide a flexible solution, the firewall section has the following features:

Firewall Enable/Disable

To access the Security Settings configuration page, on the Side Navigation bar, click on [Firewall] link.

To enable this feature, check the [Enable Firewall Module] checkbox.

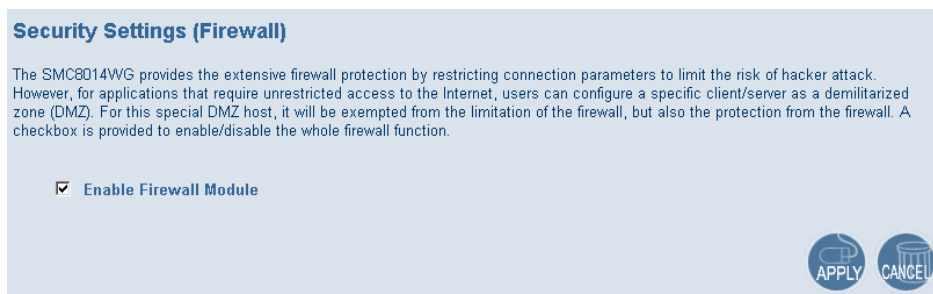

Access Control

The Access Control section allows for blocking services on the *private LAN* from accessing the Internet. Access Rules can be configured to a specific LAN IP Address or a range of LAN IP Addresses.

To access the Access Control configuration page, on the Side Navigation bar, click on [Firewall] link and then click on the [Access Control] link.

To enable this feature, check the [Enable Access Control] checkbox.

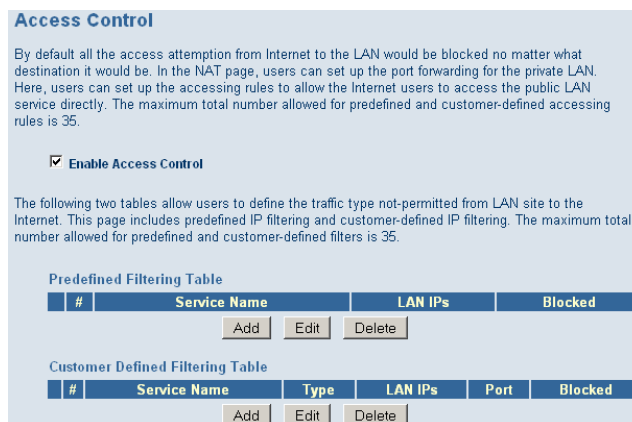

For convenience, there are two filtering options:

- Predefined Filtering
- Customer Defined Filtering

Predefined Filtering Access Rule:

1. On the Side Navigation bar, click on [Firewall] then select [Access Control]
2. Under the Predefined Section, click on the [Add] button
3. On the Predefined Filter page, select the service that you want to block from the pull-down menu

Predefined Filter

Predefined filter allows users to choose the traffic type to be blocked from LAN site to the Internet.

Service	AIM/ICQ(TCP:5190)
LAN IPs	Any
Start IP	0 0 0 0
End IP	0 0 0 0

Back Apply Cancel

4. Select the [LAN IPs] to which you want this access rule to apply. You can choose to apply this rule to Any IP Address, a Single IP Address, or a Range of IP Addresses.
 - a. Any IP Address [Any] - choose this option to block all LAN clients. You do not need to configure the [Start IP] or [End IP] options.
 - b. Single IP Address [Single address] - choose this option to block a single LAN client. Enter the LAN IP address of the PC in the [Start IP] field.
 - c. IP Address Range [Address Range] - choose this option to block a range of LAN clients. Enter the starting LAN IP address in the [Start IP] field and the ending LAN IP address of the range you want in the [End IP] field.
5. When your configuration is complete, click the [Apply] button to save your changes and return to the main Access Control page.

Customer Defined Filtering Access Rule (Custom):

1. On the Side Navigation bar, click on [Firewall] then select [Access Control].
2. Under the Customer Defined Section, click on the [Add] button.
3. On the Customer Defined Filter page, define a Name for the service/application that you want to block.

Customer Defined Filter

Customer-defined filter allows users to define their traffic type to be blocked from LAN site to the Internet.

Name	
Type	TCP
LAN IPs	Any
Start IP	0 0 0 0
End IP	0 0 0 0
From Port	
To Port	

Back Apply Cancel

NOTE: The Name is only for reference purposes.

4. Select the protocol type from the pull-down menu that you would like to block. The options are **TCP | UDP | TCP/UDP**.

5. Select the [LAN IPs] to which you want this access rule to apply. You can choose to apply this rule to Any IP Address, a Single IP Address, or a Range of IP Addresses.
 - a. Any IP Address [Any] - choose this option to block all LAN clients. You do not need to configure the [Start IP] or [End IP] options.
 - b. Single IP Address [Single address] - choose this option to block a single LAN client. Enter the LAN IP address of the PC in the [Start IP] field.
 - c. IP Address Range [Address Range] - choose this option to block a range of LAN clients. Enter the starting LAN IP address in the [Start IP] field and the ending LAN IP address of the range you want in the [End IP] field.
6. To complete the configuration, enter in the [From Port] and [To Port] information will be blocked on the network.

NOTE: Usually every application has its own corresponding port number. Users should find out the correct port number from the application vendor. For example, if you are trying to block access to a Peer-2-Peer file sharing application then you should visit that application's web site to see the ports used for that application.
7. When your configuration is complete, click the [Apply] button to save your changes and return to the main Access Control page.

Special Application

Some applications, such as Internet gaming, videoconferencing, Internet telephony, and others require multiple connections. Rules are based on the port or range of ports that the application sends data to the server on (destination port). When the Gateway sees traffic sent to the configured port(s), it dynamically allows all incoming traffic from the server on any port for the specified time.

To access the Special Application configuration page, on the Side Navigation bar, click on [Firewall] link and then click on the [Special Application] link.

To enable this option, click the [Enable Triggering] checkbox.

Special Application

Special Application allows the firewall to automatically open ports for the outgoing and incoming sessions of some multi-session protocols and applications, such as H.323, etc.

Enable Triggering

Trigger Table (up to 20 items)

#	Name	Type	Port	Interval	IP Replace	3rd Host Init
<input type="button" value="Add"/> <input type="button" value="Edit"/> <input type="button" value="Delete"/>						

To configure a Special Application Rule, follow the steps outlined below:

1. On the Side Navigation bar, click on [Firewall] then select [Special Application]
2. Click on the [Add] button on the Special Application page to access the [Trigger] configuration section.

Trigger

Users can define their port trigger here to allow the specific multiple session protocols to pass through the firewall.

Name	<input type="text"/>
Type	TCP ▾
Port Number	From <input type="text"/> To <input type="text"/>
Interval	<input type="text"/> (50 ~ 30000 ms)
IP Replacement	Disable address replacement ▾
Allow sessions initiated from/to the 3rd host	<input type="checkbox"/>

Back Apply Cancel

3. Enter in the [Name] that you want to use for this rule.
4. In the [Type] pull-down menu, select the data/traffic type that this rule will apply to. The options are *TCP* | *UDP*.
5. Configure the [Port Number] that your application will be using as the outgoing trigger ports.
6. Set the [Interval] of the rule. This is the time in between the outgoing and incoming data traffic.

NOTE: If you set this value too low, the incoming ports will be closed before the return data arrives at the firewall, the connection will be broken and the application will not work.

7. The last 2 options are for Advanced Users, most users can leave these at the default settings:
 - IR Replacement - Default Setting: Disable address replacement
 - Allow sessions initiated from/to the 3rd host - Default Setting: unchecked
8. When your configuration is complete, click the [Apply] button to save your changes and return to the main Special Application page.

URL Blocking

This section allows you to control the content on the network. This feature is good for both businesses and parents looking to control the content accessible from a web browser.

To access the URL Blocking configuration page, on the Side Navigation bar, click on [Firewall] link and then click on the [URL Blocking] link.

To enable this option, click the [Enable Keyword Blocking] checkbox

URL Blocking

You can block access to certain Web sites from all internal PCs by entering either a full URL address or just a keyword of the Web site.

You also can specify a particular PC which will be exempted from the "URL Blocking" and allowed to have full access to all web sites.

Enable Keyword Blocking

Add exempted PC [0] [0] [0] [0] [0] [0] [0] **Add Trusted Host**

Exempted PC List (up to 10 hosts):

[List Box]

Delete **Clear All**

Keyword/Domain Name [Type new Keyword/Domain here] **Add Keyword**

Blocked Keyword/Domain Name List (up to 50 items):

[List Box]

Delete **Clear All**

To configure URL blocking, follow the steps outlined below:

1. On the Side Navigation bar, click on [Firewall] then select [URL Blocking]
2. Check the [Enable Keyword Blocking] checkbox to turn URL blocking on.
3. Enter in a new keyword or URL address that you want to block in the [Keyword/Domain Name] input box.
4. Press the [Add Keyword] button to save this keyword or URL.
5. The new keyword or URL address would be listed in the text box below.

NOTE: This list will support 50 Keywords or URLs.

If you want a PC on your network to bypass these rules you will need to set that PC as an Exempted PC/Trusted Host. To configure this option, check the [Add Trusted Host] option and enter the LAN IP address of the PC that you want to bypass the URL/Keyword blocking function with.

Schedule Rule

This feature will block Internet content based on the URL blocking function for PCs on your network based on the day and/or time.

NOTE: The URL/Keyword blocking feature must be configured to use this schedule rule.

To access the Schedule Rule configuration page, on the Side Navigation bar, click on [Firewall] link and then click on the [Schedule Rule] link.

To enable this option, click the [Enable Schedule Function] checkbox.

Schedule Rule



This page defines the schedule rule you want to use with the "URL Blocking" page.

	Week Day
<input checked="" type="checkbox"/>	Every Day
<input checked="" type="checkbox"/>	Sunday
<input checked="" type="checkbox"/>	Monday
<input checked="" type="checkbox"/>	Tuesday
<input checked="" type="checkbox"/>	Wednesday
<input checked="" type="checkbox"/>	Thursday
<input checked="" type="checkbox"/>	Friday
<input checked="" type="checkbox"/>	Saturday

All Day

Start Time: [12] (hour) [0] (min) [AM] ▼

End Time: [12] (hour) [0] (min) [AM] ▼

To configure Schedule Rules, follow the steps outlined below:

1. On the Side Navigation bar, click on [Firewall] then select [Schedule Rule].
2. In the [Week Day] table check the Days that you want to apply URL/Keyword Blocking.
3. Define the appropriate settings for a schedule rule.
4. Click the [OK] button to approve rule.
5. Then click the [APPLY] button to save your settings.

Email/Syslog Alert

The Gateway can provide network log and alert information to keep you updated. The Gateway can send an e-mail to as many as 4 users alerting them of an attempted intrusion or hacker attack. The Gateway also supports a Syslog Client so you can export your Network Log entries to a Syslog Server.

To access the Email/Syslog Alert configuration page, on the Side Navigation bar, click on [Firewall] link and then click on the [Email/Syslog Alert] link.

Email/Syslog Alert

When the firewall feature is enabled, The user can be notified about the blocked traffic by email and/or syslog.

The SMC8014WG firewall can notify the user about the intrusion and/or the attempts to access the blocked URL, also the notification could be sent out immediately or by the predefined time schedule.

Mail Server Configuration

SMTP Server Address:

Sender's E-mail Address:

Mail Server Authentication

User Name:

Password:

Recipient list (up to 4 items)

Name	Email Address
<input type="text"/>	<input type="text"/>

Syslog Server Configuration

Syslog Server Address:

Alert Options

	Send Email	Send Syslog
When intrusion is detected	<input type="checkbox"/>	<input type="checkbox"/>

There are 3 sections to configure on this page:

- Email Alerting

- Syslog Alerting
- Alerting Schedule

Follow the steps below to configure the Email Alert feature:

1. Enter in your SMTP Server Address (this is also referred to as the outgoing mail server)
2. Enter in the [Sender's E-mail Address] - this is the email address that is associated with the outgoing mail server account.
3. Enter in your email [User Name].
4. Enter in your email [Password].

NOTE: If you don't have your SMTP or outgoing mail server information, please contact your cable operator.

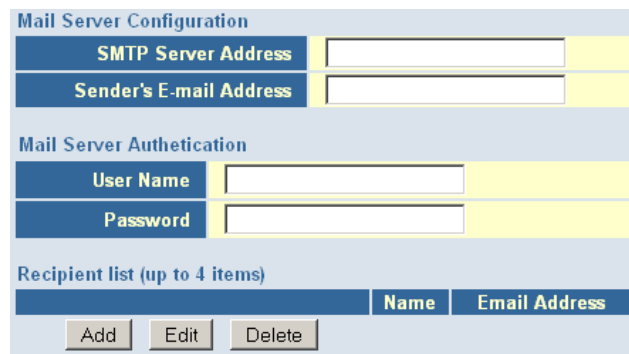

The form is titled "Mail Server Configuration" and is divided into three sections. The first section, "Mail Server Configuration", contains two input fields: "SMTP Server Address" and "Sender's E-mail Address". The second section, "Mail Server Authentication", contains two input fields: "User Name" and "Password". The third section, "Recipient list (up to 4 items)", features a table with two columns: "Name" and "Email Address". Below the table are three buttons: "Add", "Edit", and "Delete".

5. To add an email address to the Alert List, click the [Add] button. The configuration page shown below will be displayed:



The form is titled "Recipient Adding" and includes the instruction "Users could input and edit the email alert recipient list here." It contains two input fields: "Name" and "Recipient's Email Address". At the bottom of the form are three buttons: "Back", "Apply", and "Cancel".

NOTE: The email alert feature will allow you to send email alerts to 4 different email accounts. For example you could send an email to your home, work, and school email address.

6. Enter in the [Name] of the person/account that you want to send this to
7. Enter in the [Recipient's Email Address] as the email address you want to send the alert to
8. When complete, click the [Apply] button to save your settings and return to the main Email/Syslog Alert configuration page

If you need to edit or delete an existing email account, follow the steps below

1. Check the radio button next to the email entry
2. Click the [Edit] or [Delete] button.



The form is titled "Recipient list (up to 4 items)" and contains a table with two columns: "Name" and "Email Address". The table has one row with a radio button in the first column, "smc" in the second column, and "email@smc.com" in the third column. Below the table are three buttons: "Add", "Edit", and "Delete".

To enable the Syslog Alert feature, click the [Enable Syslog Alerting] checkbox.

To configure the Syslog Server, enter the LAN IP of the [Syslog Server Address].



The screenshot shows a configuration panel for Syslog Alerting. At the top, there is a checkbox labeled "Enable Syslog Alerting" which is checked. Below this, there is a label "Syslog Server Address" followed by an empty text input field.

Immediate Alerts can be generated for both the email and Syslog alerts. To configure the type of Alert that you want to get:

- An Intrusion is detected - this is a hacker attack attempt from the WAN
- Attempts to access a blocked site - alert to any attempts to access a site or keyword listed in your URL/Blocking list.

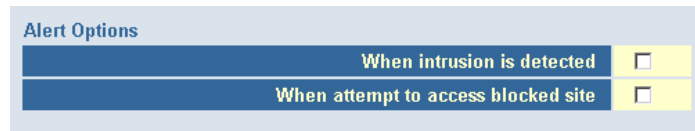

The screenshot shows the "Alert Options" section. It contains two rows, each with a label and a checkbox. The first row is "When intrusion is detected" with an unchecked checkbox. The second row is "When attempt to access blocked site" with an unchecked checkbox.

DMZ Host (Demilitarized Zone)

If you have a client PC that cannot run an Internet application properly from behind the firewall, then you can open the client up to unrestricted two-way Internet access. Enter the IP address of a DMZ host to this screen. Adding a client to the DMZ (Demilitarized Zone) may expose your local network to a variety of security risks, so only use this option as a last resort.

To access the DMZ configuration page, on the Side Navigation bar, click on [Firewall] link and then click on the [DMZ] link.

To enable this option, click the [Enable DMZ Host] checkbox.

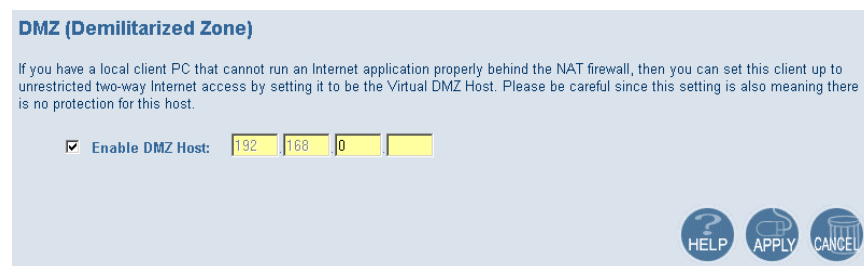

The screenshot shows the "DMZ (Demilitarized Zone)" configuration page. It includes a title, a descriptive paragraph, and a checkbox labeled "Enable DMZ Host" which is checked. To the right of the checkbox are four input fields for IP address: "192", "168", "0", and an empty field. At the bottom right, there are three circular buttons: "HELP", "APPLY", and "CANCEL".

To configure a DMZ host, Enter in the LAN IP Address of the PC on your network in the input fields.

TOOLS

The Tools menu allows a user to Restore to Factory Defaults and Reboot the Gateway.

Configuration Tools

To access the Configuration Tools configuration page, on the Side Navigation bar, click on [Tools] link and then click on the [Configuration Tools] link.

Restore to Factory Defaults

This option is used to restore to Gateway to the default settings of the last software load.

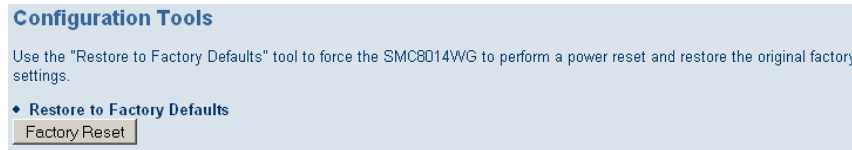

To restore your Gateway to Default Factory Settings, follow the steps below:

1. Click the [Factory Reset] button
2. Click [OK] on the confirmation dialog box

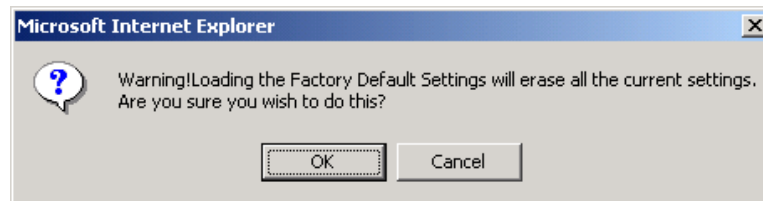

3. To complete the Restore process, click [OK] once more and the Gateway will reboot.

Reboot

In the event that the system stops responding correctly or functioning properly, you can perform a reboot.

To access the Reboot option page, on the Side Navigation bar, click on [Tools] link and then click on the [Reboot] link.

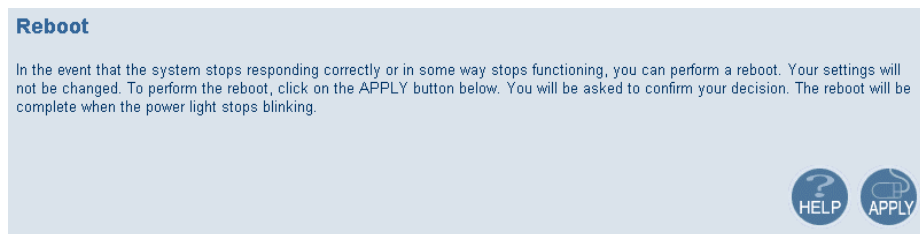

To reboot the Gateway, follow the steps below:

1. Click the [Apply] button
2. Click [OK] on the confirmation dialog box

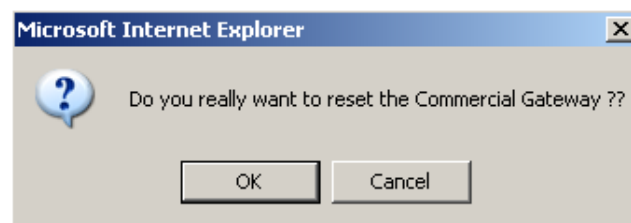

3. The Gateway will reboot.

NOTE: The Reboot will be complete when the power LED stops blinking.

STATUS

The Status screen summarizes important information about the Gateway including WAN/LAN connection status, wireless settings, software version, hardware version and uptime statistics.

Status

You can use the Status screen to see the connection status for the SMC8014WG WAN/LAN interfaces, firmware and hardware version numbers, any illegal attempts to access your network, as well as information on all DHCP client PCs currently connected to your SMC8014WG.

RG Functions: Enabled

NAT Functions: Enabled

Current Time: SAT JAN 01 00:01:03 2005 **System Up Time:** 000 days 00h:01m:17s

INTERNET WAN IP: 0.0.0.0 WAN Subnet Mask: 0.0.0.0 WAN Gateway IP: 0.0.0.0 Primary DNS: 0.0.0.0 Secondary DNS: 0.0.0.0	GATEWAY DHCP Gateway IP Address: 192.168.0.1 Subnet Mask: 255.255.255.0 DNS Proxy IP Address: 192.168.0.1	INFORMATION Software Version: 4.05.23-RRR Hardware Version: 2A RF Cable MAC Address: 00:13:F7:5E:B8:D6 USB MAC Address: 00:13:F7:5E:B8:D7 Wireless MAC Address: 00:13:F7:5E:B8:D8 RG WAN MAC Address: 00:13:F7:5E:B8:DA Serial Num: 50075EB8D6
---	---	--

WIRELESS
SSID: WLAN
Encryption Type: No Encryption
Encryption length: 0 Bits
Encryption Pass Phrase: No Encryption
Channel Being Used: 1

Interfaces Uptime and Traffic Count
LAN Uptime: 00h:01m:17s ,Receiving 14534 bytes , Sending 21202bytes
WAN Uptime: 00h:01m:17s ,Receiving 0 bytes , Sending 0bytes

The Network Log shows both firewall and network activity.

Network Log

View network activity and security logs.

```
(1/1/05 04:19:14) 192.168.0.35 mso logout  
(1/1/05 04:19:18) 192.168.0.35 mso login
```

Clear Refresh Send the Logs

The LAN Client Log lists the clients currently connected to the Gateway and the type of connection (Ethernet or Wireless). This also shows the IP address assigned to the client and the MAC Address of the client's network adapter.

LAN Client Log

View information on LAN clients currently linked to the SMC8014WG.

```
DHCP-IP:192.168.0.35, Device:cpersing, MAC:00:12:79:BD:88:A1, Interface:
```

Refresh IP Release

The Cable Modem System Event Log shows diagnostic information about the cable modem's connection and cable system.

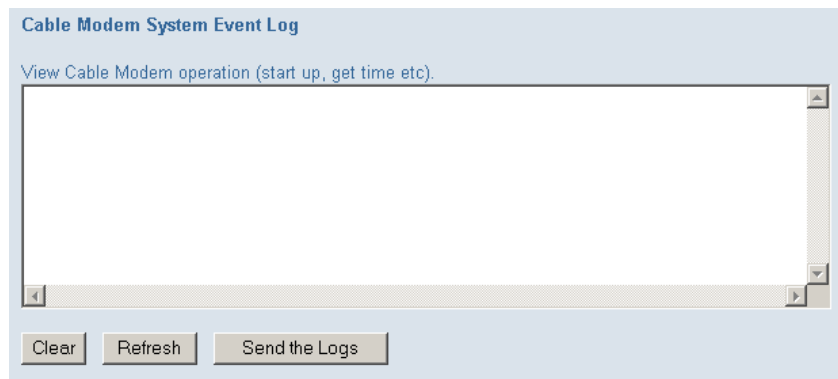

The Cable Status page shows the initialization process the SMC8014W-G has been through, as well as information about the downstream channel and the upstream channel on which the modem is connected.

Cable Status

Cable status shows the users the cable initialization procedures, also the cable downstream and upstream status.

Initialization Procedure

Initialize Hardware	Success
Acquire Downstream Channel	Success
Upstream Ranging	Success
DHCP Bound	Success
Set Time-of-Day	Success
Downloading CM Config File	Success
Registration	Success

Traffic Enable!

Downstream Channel

Downstream Frequency	609000000 Hz
Lock Status	Locked
Modulation	64 QAM
Symbol Rate	5.056941 Msym/sec
Downstream Power	-2.2 dBmV
SNR	35.128 dB

Upstream Channel

Upstream Frequency	25000000 Hz
Lock Status	Locked
Modulation	QPSK
Symbol Rate	2560000 sym/sec
Upstream Power	48.2 dBmV
Channel ID	5

APPENDIX A | Technical Specifications

<p>Compatibility</p> <ul style="list-style-type: none"> Platform independent- works with PC or MAC DOCSIS 2.0/ Cable Home 1.1 compliant certified IEEE 802.3, 802.3u and 802.11b/g compliant SPI firewall meet ICSA guidelines USB 1.1 <p>Ports</p> <ul style="list-style-type: none"> 4 10/100 NASE-TX auto MDI/MDIX 1 USB 1.1 Connector Type B 1 IEEE 802.11b/g Cable Interface F type female 75ohm <p>Cable Modem Features</p> <ul style="list-style-type: none"> DOCSIS 2.0 certified 64/256QAM auto detection Supports maximum DOCSIS transfer rates Independent resets for downstream and upstream blocks Fragmentation and concatenation enabling Quality of Server (QoS) features <p>Networking</p> <ul style="list-style-type: none"> IEEE 802.1d compliant bridging DHCP Client and Server DNS Relay ARP ICMP, FTP/TFTP, and Telnet <p>Security</p> <ul style="list-style-type: none"> Password protected configuration access Stateful Packet Inspection (SPI) Firewall Network Address Translation (NAT) Application Level Gateways (ALG) Intrusion Detection logging Denial of Service (DoS) prevention Trojan Horse Prevention Smart Tracking Domain Validation Multiple User Profiles Dynamic Address-User Mapping Web based authentication Comprehensive Logging <p>Receiver</p> <ul style="list-style-type: none"> Demodulation Max Speed:38Mnps (64QAM)/43Mbps (256QAM) Frequency Range: 91 to 857 MHz - 30 kHz 	<ul style="list-style-type: none"> Bandwith:6MHz Signal Level:-15Dbv TO +15dBmV (Automatically Gain Controlled by CM) <p>Transmitter</p> <ul style="list-style-type: none"> Modulation <ul style="list-style-type: none"> -TDMA: QPSK, 8 QAM, 16QAM, 32QAM, 64QAM -S-CDMA: QPSK, 8 QAM, 16QAM, 32QAM, 64QAM, 128QAM Max Speed: 320, 640, 1280, 2560, 5120kbps (QPSK) ; 640, 1280, 2560, 5120, 10240kbps (16QAM) Frequency Range: 5 to 42MHz (edge to edge) Bandwidth: 0.2, 0.4, 0.8, 1.6, 3.2MHz <ul style="list-style-type: none"> - TDMA: 200, 400, 800, 1600, 3200 and 6400 kHz - S-CDMA: 1600, 3200 and 6400 kHz Signal Level: +8dBmV to +58dBmV (QPSK); +8dBmV to +55dBmV (16QAM) - TDMA: +8 to +54 dBmV (32QAM, 64QAM); +8 to +55 dBmV (8QAM, 16QAM); +8 to +58 dBmV (QPSK) - S-CDMA: +8 to +53 dBmV (all modulations) (Output level of CM can automatically controlled by CMTS through power ranging function), Step: 3Db Output Return Loss: > 6 dB (5-42 MHz) and (91~857 Mhz) <p>Output Power</p> <ul style="list-style-type: none"> -54MBPS OFDM: +12~14DBM; 11MBPSCCK: 18DBM <p>Receiver Sensitivity</p> <ul style="list-style-type: none"> -72DBM AT 54MPBS, 10% PER -72DBM AT 48MPBS, 10% PER -75DBM AT 36MPBS, 10% PER -79DBM AT 24MPBS, 10% PER -82DBM AT 18MPBS, 10% PER -83DBM AT 22MPBS, 8% PER -82DBM AT 11MPBS, 8% PER -87DBM AT 9MPBS, 10% PER -88DBM AT 6MPBS, 10% PER -85DBM AT 5.5MPBS, 8% PER -86DBM AT 2MPBS, 8% PER -89DBM AT 1MPBS, 8% PER <p>Connector</p> <ul style="list-style-type: none"> 2-RP-SMA
--	--

<p>Number of SSIDs: 16</p> <p>Filtering</p> <ul style="list-style-type: none"> • LLC: 16 • IP: 16 <p>Frequency Search</p> <ul style="list-style-type: none"> • Frequency Cache : 4 entries Frequency • Channel Plan: 6 Hz step <p>OSS</p> <ul style="list-style-type: none"> • Protocol: ICMP/SNMP V1, V2c, V3 • MIB: MIB II / MCNS MIB <p>Regulatory Certification</p> <ul style="list-style-type: none"> • FCC Part 15 Class B • EN60950 , UL1950 • CE <p>LED Power, Diag, Cable Link, Cable Traffic, Wireless, Local Area Network, USB</p>	<p>MAX. of CPEs</p> <ul style="list-style-type: none"> • 32 (32 MAC addresses) <p>Environment</p> <ul style="list-style-type: none"> • Operating Temperature: 32°F (0°C) to 104°F (40°C) • Operating Humidity: 10% to 90% (Non condensing) • Storage Temperature: -4°F (-20°C) to 140°F (60°C) <p>Power Supply Adapter 120V ±10 %, 50/60Hz Consumption: 9W (Standby), 10W (operation)</p> <p>Size: (W x H x D)</p> <ul style="list-style-type: none"> • 9.17 x 5.9 x 1.5 in <p>Weight</p> <ul style="list-style-type: none"> • .84lbs
--	---

APPENDIX B | Compliances

FCC Interference Statement

This equipment has been tested and found to comply with the limits for a Class B digital device pursuant to Part 15 of the FCC Rules. These limits are designed to provide reasonable protection against radio interference in a commercial environment. This equipment can generate, use and radiate radio frequency energy and, if not installed and used in accordance with the instructions in this manual, may cause harmful interference to radio communications. Operation of this equipment in a residential area is likely to cause interference, in which case the user, at his own expense, will be required to take whatever measures are necessary to correct the interference. If this equipment does cause harmful interference to radio or television reception, which can be determined by turning the equipment off and on, the user is encouraged to try to correct the interference by one of the following measures:

- Reorient or relocate the receiving antenna.
- Increase the separation between the equipment and receiver.
- Connect the equipment into an outlet on a circuit different from that to which the receiver is connected.
- Consult the dealer or an experienced radio/TV technician for help.

The device complies with Part 15 of the FCC Rules. Operation is subject to the following two conditions: (1) This device may not cause harmful interference, and (2) this device must accept any interference received, including interference that may cause undesired operation.

FCC Caution: Any changes or modifications not expressly approved by the party responsible for compliance could void the user's authority to operate this equipment.

IEEE 802.11b or 802.11g operation of this product in the U.S.A is firmware-limited to channels 1 through 11.

IMPORTANT NOTE:

FCC Radiation Exposure Statement:

This equipment complies with FCC radiation exposure limits set forth for an uncontrolled environment. This equipment should be installed and operated with minimum distance 20cm between the radiator & your body. This transmitter must not be co-located or operating in conjunction with any other antenna or transmitter. The availability of some specific channels and/or operational frequency bands are country dependent and are firmware programmed at the factory to match the intended destination. The firmware setting is not accessible by the end user.

CE Declaration of Conformity

This equipment complies with the requirements relating to electromagnetic compatibility, EN 55022/A1 Class B, and EN 50082-1. This meets the essential protection requirements of the European Council Directive 89/336/EEC on the approximation of the laws of the member states relation to electromagnetic compatibility.

Compliances

APPENDIX C | Technical Support

At this time, the SMC8014W-G is only distributed through cable operators. Contact your cable operator with any technical support needs you may have.

SMC Networks, Inc.
20 Mason
Irvine, CA
92618

Rev. 09/2009

SMC8014W-G